

Unité d'avance UA 40
 Vorschubschlitten UA 40
 Slide unit UA 40

www.somex.eu

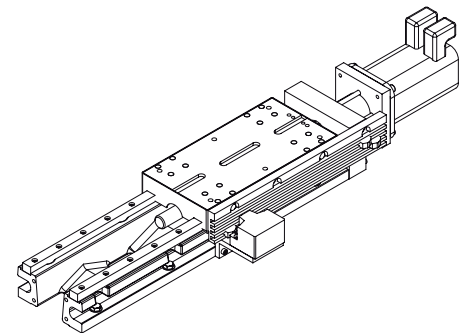
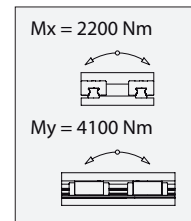
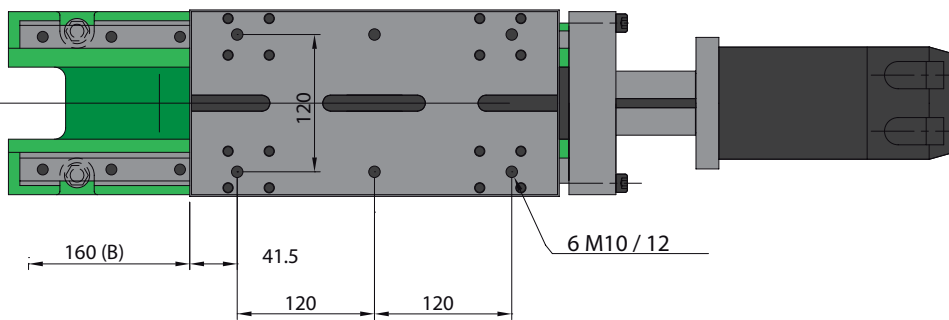
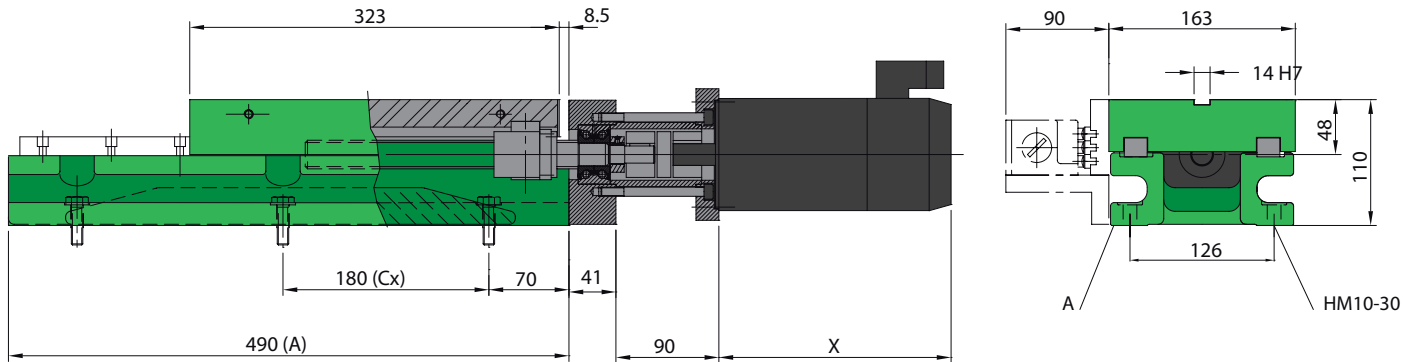

| | A | B | C |
|-----------|-----|-----|---|
| UA40CA160 | 490 | 160 | 2 |
| UA40CA320 | 660 | 320 | 3 |
| UA40CA480 | 840 | 480 | 4 |

A: Face de référence
 A: Referenzfläche
 A: reference surface

UA 40OP Unité oléo-pneumatique
 UA 40H Unité hydraulique
 UA 40CN Unité à commande numérique

UA 40OP Pneumohydraulisch
 UA 40H Hydraulisch
 UA 40CN Kugelumlaufspindel

UA 40OP hydro-pneumatic
 UA 40H hydraulic
 UA 40CN ball screw

| Caractéristiques techniques | |
|-----------------------------|--------------|
| Pas de la vis à billes | 5 mm, X25 mm |
| Précision | 23µ/300 |
| Vitesse d'avance max. | 20 m/min |
| Effort de poussée (2 sens) | 5500 N |
| Servomoteur | 8 Nm |
| Poids (course 160) | 45 kg |
| Poids (course 320) | 55 kg |
| Poids (course 480) | 65 kg |

| Technische Daten | |
|------------------------------|--------------|
| Steigung der Spindel | 5 mm, X25 mm |
| Genauigkeit | 23µ/300 |
| Max. Vorschubgeschwindigkeit | 20 m/min |
| Vorschubkraft (2-Weg) | 5500 N |
| Servomotor | 8 Nm |
| Gewicht (Hub 160) | 45 kg |
| Gewicht (Hub 320) | 55 kg |
| Gewicht (Hub 480) | 65 kg |

| Technical Data | |
|---------------------------|--------------|
| Ball screw pitch | 5 mm, X25 mm |
| Accuracy | 23µ/300 |
| Max. feed rate | 20 m/min |
| Thrust in both directions | 5500 N |
| Servomotor | 8 Nm |
| Weight (stroke 160) | 45 kg |
| Weight (stroke 320) | 55 kg |
| Weight (stroke 480) | 65 kg |