

## Adaptateurs à changement rapide et porte-outils pour le taraudage

AD 00	
∅ mm	∇ mm
2,24	1,80
2,50	2,10
2,50	2,00
2,80	2,24
2,80	2,10
3,50	2,70
3,15	2,50
3,55	2,80
4,00	3,15
4,00	3,00
4,50	3,50
4,50	3,40
5,00	4,00
5,60	4,50
6,00	4,90
6,30	5,00

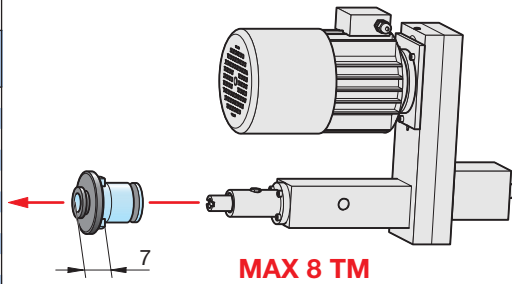

AD 01	
∅ mm	∇ mm
2,80	2,10
3,15	2,50
3,50	2,70
4,00	3,15
4,00	3,00
4,50	3,40
4,50	3,55
6,00	4,90
6,50	5,00
7,00	5,50
7,10	5,60
8,00	6,20
9,00	7,00
9,00	7,10
10,00	8,00
11,00	9,00
11,20	9,00
12,00	9,00

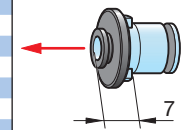

AD 02	
∅ mm	∇ mm
6,0	4,9
6,3	5,0
7,0	5,5
7,1	5,6
8,0	6,3
8,0	6,2
9,0	7,0
9,0	7,1
10,0	8,0
10,0	8,0
11,0	9,0
11,2	9,0
12,0	9,0
12,5	10,0
14,0	11,0
14,0	11,2
16,0	12,0
18,0	14,5

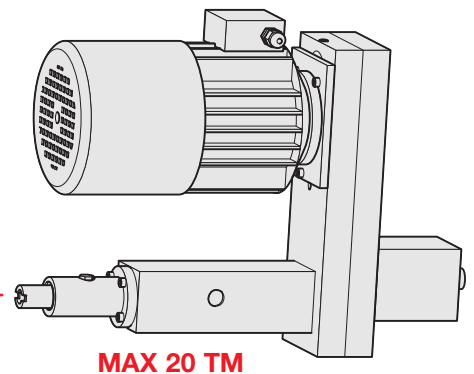
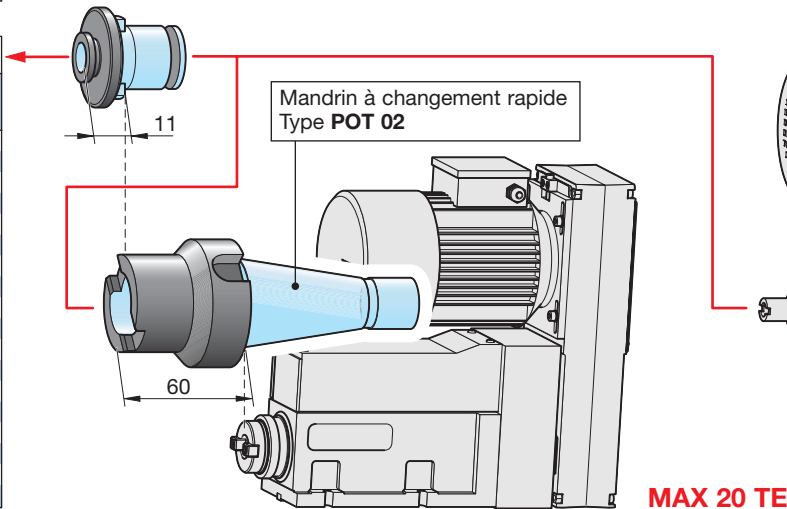

## Douilles DIN à changement rapide

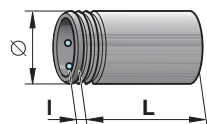
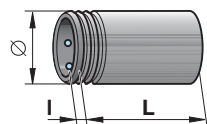
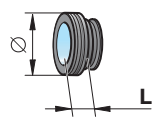
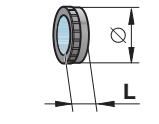
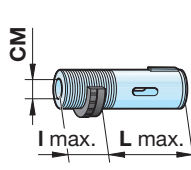
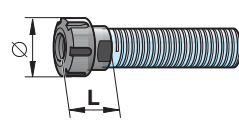
Se monte sur:	Type	Cotations pour implantation			Désignation
MAX 6 F	ASBA 12	L=61	l= 9	∅24	 Douille pour changement rapide sur broche DIN 55058
	ASBA 16	L=77	l=10	∅30	
	ASBA 20	L=83	l=11	∅38	
	ASBA 25	L=91	l=12	∅45	
MAX 12 F	ASBA 28	L=93	l=14	∅48	
	SSM 12	L= 9	∅22	 Ecrin de réglage sur porte-outil pour changement rapide	
MAX 6 F	SSM 16	L= 9	∅30		
	SSM 20	L= 9	∅33		
	SSM 25	L=12	∅45		
MAX 12 F	SSM 28	L=12	∅45	 Ecrin de réglage sur porte-outil pour broche DIN 55058	
MAX 6 F	SM 12	L= 6	∅20		
	SM 16	L=12	∅25		
	SM 20	L=12	∅32		
	SM 25	L=12	∅37		
MAX 12 F	SM 28	L=12	∅40	 Broche douille DIN 6327, CM 0 à CM 2. Version longue sur demande	
MAX 6 F	D 12-6	Métr. 6	L=53		l=25
MAX 6 F	D 16/0-MK 0	CM 0	L=76		l=37
	D 16/1-MK 1	CM 1	L=76		l=37
MAX 12 F	D 20/1-MK 1	CM 1	L=79		l=37
	D 25/1-MK 1	CM 1	L=85		l=38
MAX 12 F	D 25/2-MK 2	CM 2	L=85		l=38
MAX 12 F	D 28/1-MK 1	CM 1	L=85		l=38
MAX 6 F	SH 12/ER 11	L=35	∅16	 Porte-outil pour pinces ER 11 à ER 25	
	SH 16/ER 16	L=27	∅19		
	SH 20/ER 20	L=29	∅34		
	SH 25/ER 25	L=31	∅42		
MAX 12 F	SH 28/ER 25	L=31	∅42		